

Locomotion Control of Legged Robots using Nonlinear Oscillators

Kazuo TSUCHIYA, Katsuyoshi TSUJITA and Shinya AOI

Dept. of Aeronautics and Astronautics,
Kyoto University
Yoshida-honmachi, Sakyo-ku, Kyoto 606-8501, Japan

Abstract. This paper deals with locomotion control of legged robots using nonlinear oscillators. The proposed control system is composed of a motion plan system and a motion control system. The motion plan system is composed of a motion generator and a trajectory generator. The nonlinear oscillators in the motion generator tune the phases through the feedback signals from the touch sensors at the tips of the legs as well as mutual interactions. The trajectory generator encodes a nominal trajectory of each joint angle in terms of phase of the corresponding oscillator, and the motor controllers in the motion control system drive the joint motors in order to realize the desired motion generated by the motion plan system. As a result, the proposed controller can adapt to a dynamic environment by changing the locomotion pattern. Moreover, it does not depend on a detailed model of the robot, and thus it can be widely applied to various types of legged robots. In this paper, by applying the proposed control system to two types of legged robots, a quadruped robot and a biped robot, the advantages of the controller are demonstrated by numerical simulations and hardware experiments.

1 Introduction

A legged robot is a mechanical system composed of many links through rotational joints. The legged robot's locomotion is regarded as a rhythmic motion of a mechanical system with many degrees of freedom. Locomotion control of the legged robot implies control of such rhythmic motion. In some cases, a biped robot or a quadruped robot becomes unstable in attitude during locomotion. This type of locomotion is called dynamic locomotion.

This article deals with the design method of a control system for biped and quadruped robots, with emphasis on the control for dynamic locomotion. Usually, the motion control of a mechanical system with many degrees of freedom is achieved by a model-based approach[1]. This kind of control system consists of a motion plan system and a motion control system. The motion plan system generates the nominal trajectory of the mechanical system, and the motion control system controls each joint to realize the nominal trajectory. Based on the model-based approach, the locomotion control system of the legged robot can be designed as follows. The motion plan system is composed of a family of periodic functions in which the nominal angular positions of the joints are encoded in such a way to achieve stable and periodic

nominal locomotion. On the other hand, the motion control system is composed of a local feedback controller that controls the motors equipped at the joints receiving the nominal angular joint positions as commanded signals. This type of control system is neither always robust against disturbances nor able to adapt to variations in the environment.

There are two ways to overcome these difficulties. One is a method to modify the motion control system. This involves modifying the commanded signals by utilizing the signals of sensors such as an angular rate sensor, touch sensors equipped at the end of the robot's legs, etc. The other method is to modify the motion plan system. This involves designing the motion plan system as a dynamical system[2][3]. The nominal angular positions of the joints are encoded as states of the dynamic system. By inputting the signals of the sensors, the state of the dynamic system is changed according to the dynamic variances of the environment. As a result, the nominal locomotion, as well as the nominal angular position of the joints, is appropriately generated according to the variations in the environment.

The authors have been developing a control system for biped and quadruped robots by applying the latter method[4][5]. Our proposed control system is designed as follows. The motion plan system is composed of a motion generator and a trajectory generator. The motion generator consists of nonlinear oscillators, each of which has a stable limit cycle. The nonlinear oscillators have input signals from the touch sensors equipped at the end of the legs as well as mutual interactions with each other. As a result, each oscillator tunes a phase according to the variations in the environment. On the other hand, the trajectory generator generates the nominal values of the angular position of the joints as functions of phase of the corresponding oscillator. As a result, changing a locomotion pattern, the robot with the proposed controller can walk stably in a dynamic environment.

This article introduces our proposed control system for legged robots using nonlinear oscillator. As examples of this study, a biped and a quadruped robots are introduced, and the proposed control system is designed for these legged robots. The efficiency and performance of our approach are verified through numerical simulations and hardware experiments.

2 Mechanical Model

Here, we consider quadruped and biped robots. The quadruped robot is shown in Fig.1, which has four legs and a body. Each leg is composed of two links which are connected to each other through a one degree of freedom rotational joint. Legs are numbered from leg 1 to 4, as shown in Fig.1. The joints of each leg are numbered as joint 1 and 2 from the body toward the tip of the leg.

On the other hand, the biped robot is shown in Fig.2. The robot consists of a body, a pair of arms composed of four links and a pair of legs composed

of six links. Each link is connected to each other through a one degree of freedom rotational joint. Left and right arms are numbered as arm 1 and arm 2, respectively. The joints and the links of arms are numbered as joint 1,2,..., and link 1,2,... from the body to the tip of the hand. The legs are numbered in a similar manner.

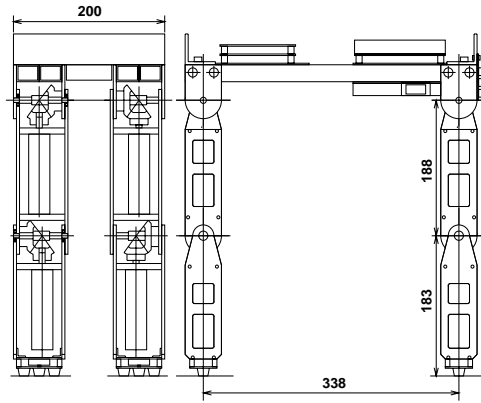

Fig.1. Schematic model of quadruped robot

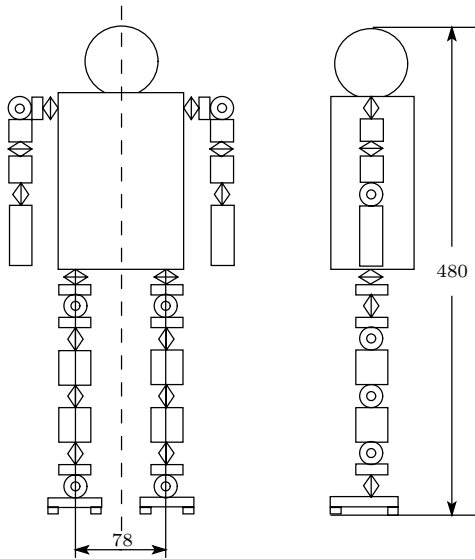

Fig.2. Schematic model of biped robot

3 Locomotion Control

The architecture of the proposed control system is shown in Fig.3. The control system is composed of a motion plan system and a motion control system. The motion plan system is composed of a motion generator and a trajectory generator. Nonlinear oscillators in the motion generator tune the phases through mutual interactions and the feedback signals from the touch sensors. The trajectory generator encodes the nominal trajectory of each joint angle in terms of phase of the oscillators, which is given to the motion controller as the commanded signal. The motor controllers in the motion control system drive all the joint motors so as to realize the desired motions that are generated by the motion plan system.

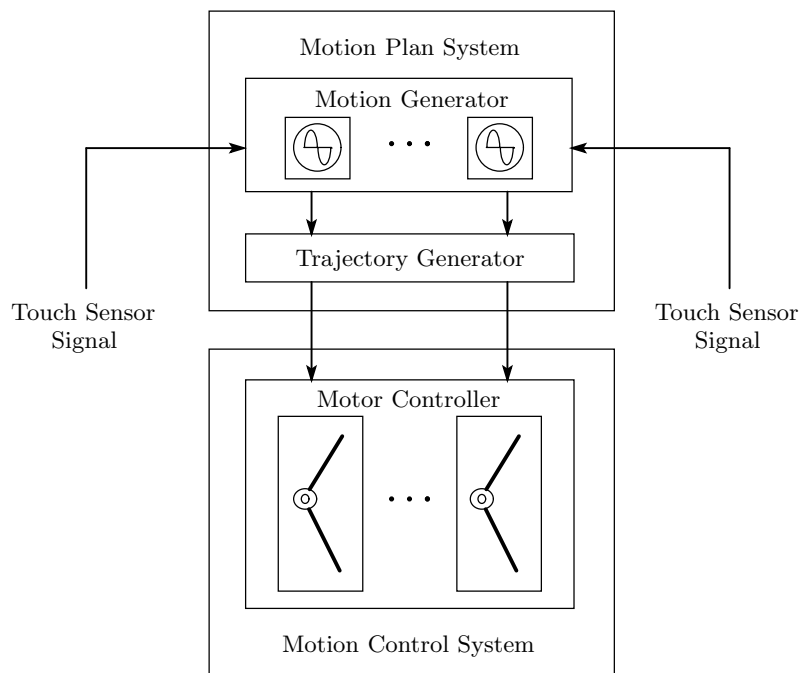
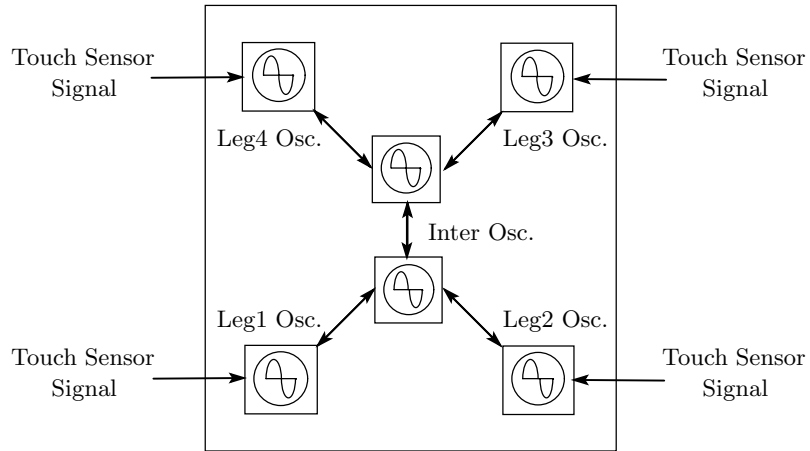
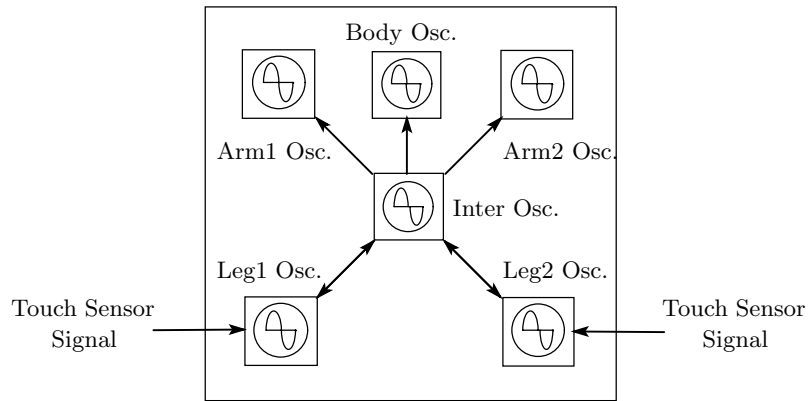

Fig.3. Architecture of Locomotion Control System

The motion of the quadruped robot is determined by specifying the motions of the tips of the four legs. On the other hand, the motion of the biped robot is determined by specifying the motions of the tips of the two legs and two arms as well as the attitude motion of the body. The motion generator is composed of two kinds of nonlinear oscillators (Fig.4). One is a set of motor oscillators which correspond to the motions to be specified. Another is a set



(a) quadruped robot



(b) biped robot

Fig.4. Motion Generator

of inter oscillators which connect the oscillators. Four motor oscillators corresponding to the legs' motion and two inter-oscillators compose the oscillator network for the quadruped robot, while five motor oscillators corresponding to the legs', arms' and bodys' motion and one inter-oscillator compose the network for the biped robot. The motion oscillators encode the trajectories of the corresponding motions in terms of their phases. The nominal trajectory of the tip of each leg is designed for both quadruped and biped robots as follows. Two trajectories are given: One is the nominal trajectory for the swinging phase, and the other is that for the supporting phase (Fig.5). For

the tip of leg i , two typical points, $r_{AEP}^{(i)}$, anterior extreme position (AEP) and $r_{PEP}^{(i)}$, posterior extreme position (PEP), are defined relative to the body. The trajectory for the swinging phase $\eta_{Sw}^{(i)}$ is a closed curve involving AEP and PEP. On the other hand, the trajectory for the supporting phase $\eta_{Sp}^{(i)}$ is a line connecting AEP and PEP. These two trajectories are switched at AEP and PEP. This involves switching from the swinging phase to the supporting phase at AEP and from the supporting phase to the swinging phase at PEP. Moreover, for the biped robot, the nominal trajectories of the arms and the body are given as closed curves in terms of the phases of the corresponding motor oscillators. In the motion generator, the angle of each joint is calculated from these nominal trajectories by means of the inverse kinematics. The angles of the joints are given to the motion controller as the commanded signals.

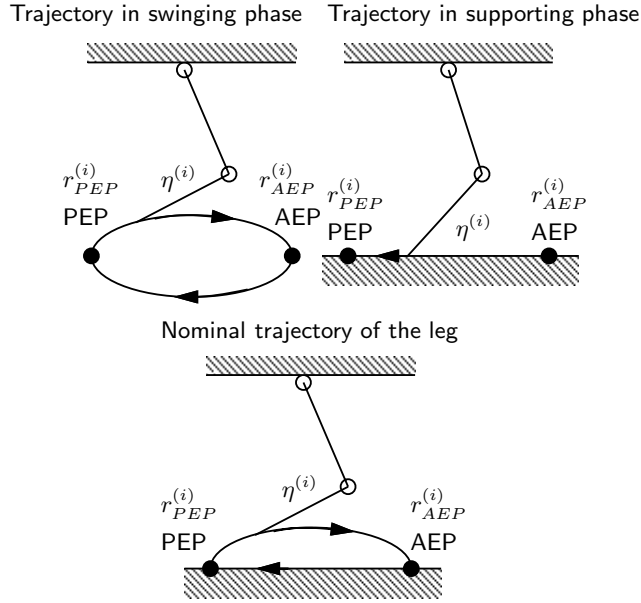

Fig.5. Trajectory of the leg

The dynamics of the oscillators in the motion generator is designed as follows. A phase dynamics is used for the design of the oscillator network[6].

$$\dot{\phi}^{(i)} = \omega + g^{(i)} \quad (1)$$

where $\phi^{(i)}$ is a phase of oscillator i , ω is an angular velocity of the oscillator and $g^{(i)}$ is an influence term from other oscillators and an environment. Each

oscillator has mutual interactions with other oscillators (Fig.4). In the cases of both quadruped and biped robots, each motor oscillator corresponding to a leg's motion has mutual interactions with the inter-oscillators. Moreover, in the case of the biped robot, each motor oscillator corresponding to an arm's motion and the attitude motion of the body receive unidirectional influence from the inter-oscillator. These interactions form an inherent phase relationship among the oscillators, and then, an inherent locomotion pattern emerges.

On the other hand, each oscillator corresponding to the leg motion receives a sensor signal of the touch sensor equipped at the tip of the leg as a feedback signal. As soon as the touch sensor signal inputs to the oscillator, the phase of the motor oscillator shifts to the value corresponding to that at the AEP in the nominal motion. At the same time, the trajectory changes from that of the swinging stage to that of the supporting stage. This means that, by using the feedback signal from the touch sensor, the oscillator tunes the phase according to the variations in the environment. This also leads to variation of commanded signals from the motion generator to the motion controller. As a result, the legged robot achieves an adaptive locomotion pattern to cope with variations in the environment.

4 Numerical simulation

Numerical simulations are implemented to verify the performances of the proposed control system, with emphasis on the robustness of steady locomotion against the variation in the environment.

First, numerical simulations are carried out for the quadruped robot. A steady locomotion is a periodic motion and its stability can be verified by using Floquet Theorem. Poincaré map along the periodic orbit is obtained and then stability of the locomotion is evaluated by checking the maximum norm of eigen values of Poincaré map. The nominal duty ratio $\hat{\beta}$, the ratio between the time of the supporting phase and the period of one step of locomotion, is selected as a parameter. The inherent gait pattern is set to be a trot. One example is shown in Fig.6. We can find that the robot established stable locomotion in a wide parameter range.

The gait patterns generated in a steady locomotion are examined. Figures 7 are examples of the obtained gait pattern. In these figures, solid line indicates supporting phase and blank one is swinging phase. The figures show that in the case where duty ratio $\hat{\beta}$ is small, a trot is established whereas in the case where duty ratio $\hat{\beta}$ is large, a transverse walk is established. This figure reveals the mechanism how the quadruped robot with the proposed control system can walk stably in a dynamic environment. The oscillators in the motion generator tune the phases according to the variation in the environment. This, in turn, results in the phase relationship among the oscillations varying according to the variations in the environment. As a result,

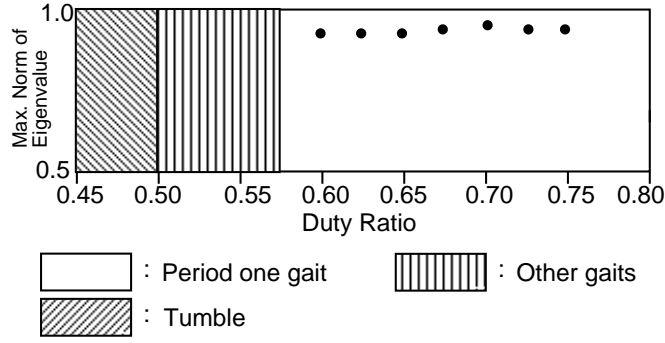

Fig.6. Stability of locomotion

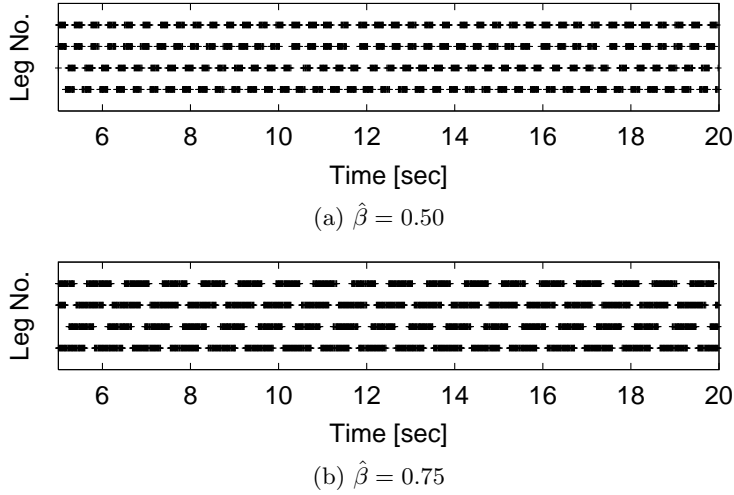

Fig.7. Gait pattern diagram

the quadruped robot achieves an adaptive gait pattern to cope with the variations in the environment.

Next, numerical simulations are carried out for the biped robot. The nominal trajectories of all the joints are determined so that the biped locomotion robot can walk stably in a certain fixed environment. In order to verify the effectiveness of the proposed control system, the simulations of the model-based control system without phases tuning (Conventional) are also investigated. As a change of the environment, the nominal locomotion speed is changed by changing the nominal stride. The results are shown in Fig.8. This figure shows the period of locomotion, the interval between the times when the left

leg makes contact with the ground. From this figure, it is revealed that the robot with the proposed control system can walk in a wide velocity region by changing the period of the locomotion.

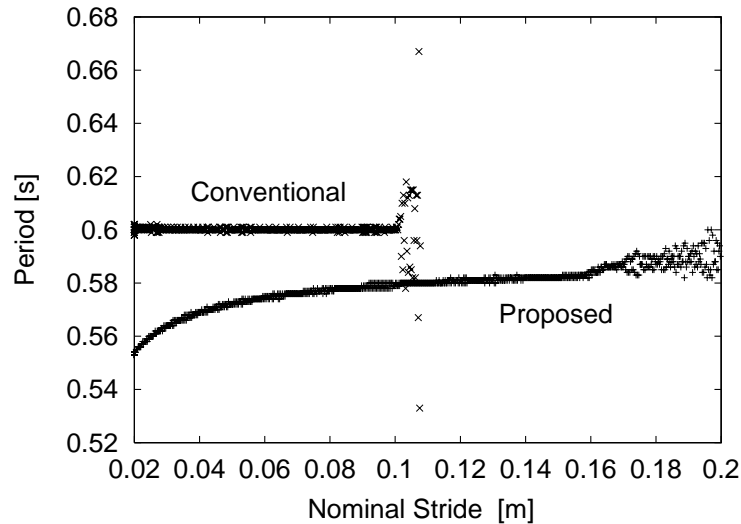

Fig.8. Period of locomotion

5 Hardware experiment

Performance of the proposed control system is verified also by hardware experiments.

Figure 9 shows the photograph of the hardware model of quadruped robot. Figure 10 shows the gait pattern diagram. The figure shows that the robot with the proposed control system establishes steady locomotion for each duty ratio $\hat{\beta}$ by changing its gait pattern.

Fig.11 shows the photograph of the hardware model of biped robot. The nominal locomotion speed is changed gradually by changing the nominal stride. The results are shown in Fig.12. This figure shows the profiles of the period of inter oscillator. From these figures, it is shown that the robot with the proposed control system can walk adaptively to the variation of the environments by tuning the period of the locomotion.

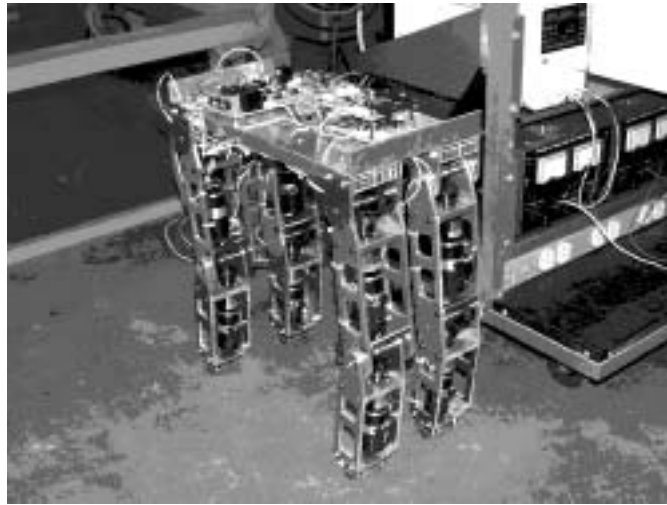
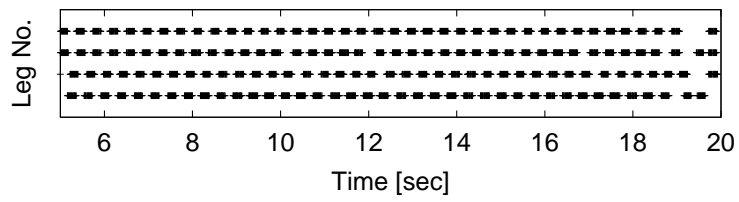
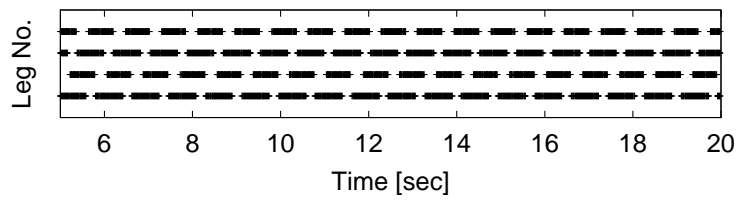

Fig.9. Hardware model of quadruped robot



(a) $\hat{\beta} = 0.50$



(b) $\hat{\beta} = 0.75$

Fig.10. Gait pattern diagram



Fig.11. Hardware model of biped robot, HOAP-1 (Fujitsu)

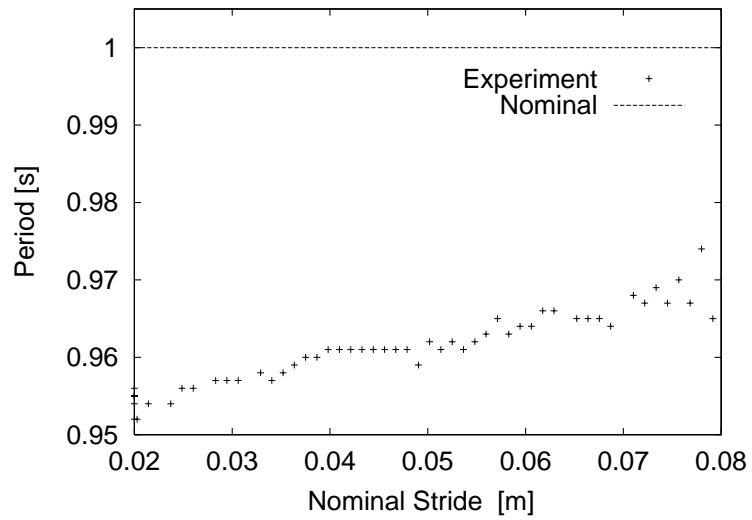

Fig.12. Period of locomotion

References

1. An C.H., Atkeson C.G., and Hollerbach J.M. (1988) Model-based control of a robot manipulator, MIT Press
2. Ijspeert A.J., Nakanishi J. and Schaal S. (2001) Trajectory Formation for Imitation with Nonlinear Dynamical Systems, Proc. IEEE/RSJ Int Conf on Intelligent Robots and Systems (IROS 2001), pp.752–757
3. Ijspeert A.J., Nakanishi J. and Schaal S. (2002) Learning Rhythmic Movements by Demonstration using Nonlinear Oscillators, Proc. IEEE/RSJ Int Conf on Intelligent Robots and Systems (IROS 2002), pp.958–963
4. Tsujita K., Tsuchiya K. and Onat A. (2001) Adaptive Gait Pattern Control of a Quadruped Locomotion Robot, Proc. IEEE/RSJ Int Conf on Intelligent Robots and Systems (IROS 2001), pp.2318–2325
5. Tsuchiya K. Aoi S. and Tsujita K. (2003) Locomotion Control of a Biped Locomotion Robot using Nonlinear Oscillators, Presented at IEEE/RSJ Int Conf on Intelligent Robots and Systems (IROS 2003)
6. Kuramoto Y. (1984) Chemical Oscillations, Wave and Turbulence, Springer, Berlin